



Cemar Electro Inc.

CL-800 Series Lasers

Model	Optical Power	Line Length	Line Width/Dot Size	Source	Wavelength	Laser Class
CL-800	0.9 mW	Dot	1mm @ 25.4mm to 6mm @ 16.7m distance 1/32 inch @ 1 inch to 1/4 inch @ 50-foot distance	Solid State Laser Diode	670 nm (dark red)	 <p>Class II Laser Product 1mW max 670 nm or 635nm.</p> <p>This product complies with provisions of US 21CFR 1040.10 and 1040.11.</p>
CL-801	5 mW	Up to 1.0m (3 feet)	1.0mm @ 1m distance 0.04 inch @ 3 feet			
CL-805	5 mW	Up to 2.5m (8 feet)	1.0mm @ 3m distance 0.04 inch @ 10 feet			
CL-810	10 mW	Up to 4.0m (12 feet)	1.0mm @ 3m distance 0.04 inch @ 10 feet			
CL-815	15 mW	Up to 10.0m (30 feet)	1.0mm @ 3m distance 0.04 inch @ 10 feet			
CL-820	20 mW	Up to 15.0m (45 feet)	1.0mm @ 3m distance 0.04 inch @ 10 feet			
CL-830	30 mW	Up to 20.0m (60 feet)	1.0mm @ 3m distance 0.04 inch @ 10 feet			
					635 nm (bright red)	

Electrical Specifications

For all CL-800 Series lasers.

Power Supply	90 ~ 240 VAC or 9 ~ 35VDC
Approvals	
Laser Consumption	1 Watt max.
Operating Ambient Temperature	-10° to +40° C (14° to 100° F)

** Call us for additional power input options. We can provide an option to suit your needs.

Custom Lasers

Cemar Electro Inc. develops custom lasers for your special application. Call our sales department for a free assessment of your needs.



Cemar Electro Inc.

CL-800 Dimensional Diagrams

Standard Bracket

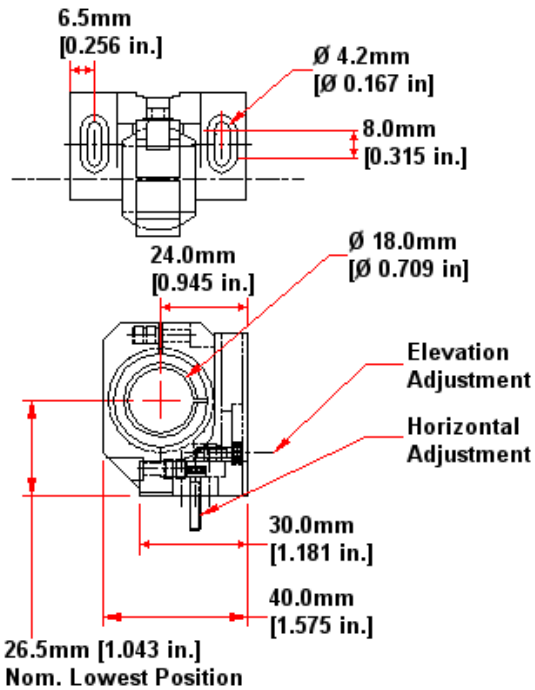

Bracket height:
50.3 mm (1.98 inches)

Elevation range:
6.6 mm (0.26 inches)

Laser and Power Supply – Side View

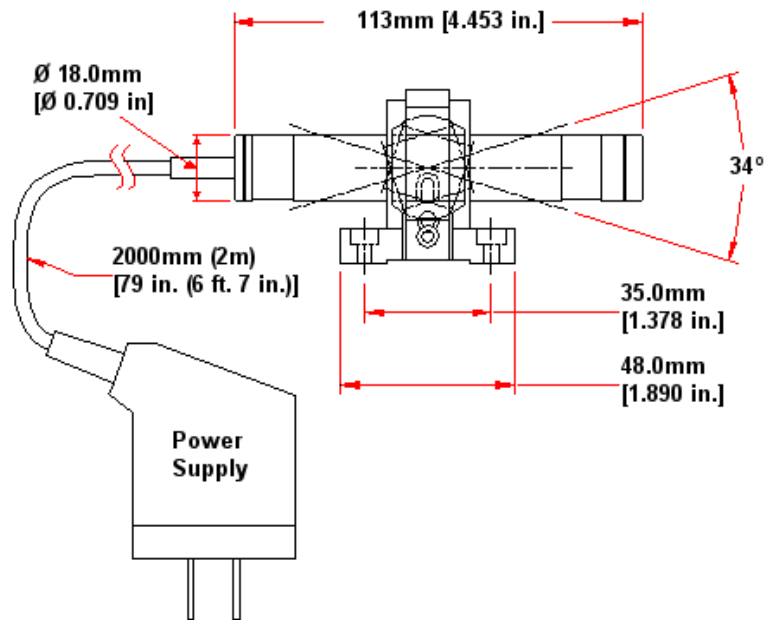

Warranty

Most CEMARLIGNE lasers are warranted against manufacturing defects for one (1) year from the date of purchase.

Service

Send lasers for service to Cemar Electro Inc. for a free repair estimate. All lasers are serviced and shipped to the customers within 48 hours of an accepted estimate. Repair time includes testing and burn-in.

Contact Cemar Electro Inc.

Head Office

Cemar Electro Inc.
528 Meloche
Dorval, Quebec
H9P 2T2

phone: 514-631-5807
fax: 514-631-7505
toll free: 1-877-631-5273

email: cemar@cemarelectro.com

U.S. Office

Cemar Electro Inc.
100 Walnut Street
Champlain, NY
12919, USA

phone: 518-298-3065
fax: 518-298-2927
toll free: 1-800-298-5273

email: cemarusa@cemarelectro.com

Europe Representative

P. Spirig GMBH
Bahnstrasse 23
CH-9435 Heerbrugg
Switzerland

phone: 41-71 722 3820
fax: 41-71 722 7887

email: cemareurope@cemarelectro.com

© Cemar Electro Inc., 2002

CEMARLIGNE

www.cemarelectro.com

